

<p>Product Specification</p> <p>Secure Flip 28mm PCO 1881</p> <p>Ref.: 2896 V5</p>	<p>Rev. 1</p> <p>09.07.2018</p> <p>page 1 of 5</p>	
---	--	--

Picture of cap



product

Ref.	TE band	Neck finish	Finish diameter (mm)	Neck Ref.
2896	slitted	PCO 1881	28	C2158

product properties

Ref.	Characteristic	Remark
2896	Flip Top cap	one hand opening hinge cap
2896	opening angle	160°
2896	number of pieces	3
2896	spout	without valve
2896	tamper evidence	tamper evident ring for the lid cap
2896	tamper evidence	lower tamper evident band slitted and folded
2896	aseptic properties	drainage holes at spout area –to be confirmed with different treatment systems

Product Specification Secure Flip 28mm PCO 1881 Ref.: 2896 V5	Rev. 1 09.07.2018 page 2 of 5	
--	--	--

safety

Ref.	Characteristic	Remark
2896	hinge according to toy regulation EN 71-1_2011	Apply torque until 0,34 Nm or 180° + traction 90N in 5s during 10s , no breaking

cap dimensions (see drawing)

Ref. 2896	Dimensions	value (mm)
	total height	30,4 +/- 0,3
	plug seal diameter	22,4 +/- 0,2
	outer diameter TE	30,5 +/- 0,3
	outer diameter knurling	29,2 +/- 0,2
	total weight	3,945 g +/- 0,25 g
	number of knurls	72

material

Ref.	part	material type	name of approved material
2895	Body	PP	LyondellBasell Clyrell EC348P
2894	Spout	HDPE organo	Ineos Eltex HD6070 EA-B
2893	Ring	HDPE organo	Ineos Eltex HD6070 EA-B
Masterbatch	all	adapted to carrier material	possibility to combine 3 different colors

<p>Product Specification</p> <p>Secure Flip 28mm PCO 1881</p> <p>Ref.: 2896 V5</p>	<p>Rev. 1</p> <p>09.07.2018</p> <p>page 3 of 5</p>	
---	---	--

sealing

Ref.	before 1st opening	after 1st opening
2896	36 Psi (2.5 bar) on average	22 Psi (1.5 bar) on average

opening lid cap force

Ref.	1st opening force	2nd opening force
2896	10 to 25 N	9 to 14 N

application

Ref.	application torque	head pressure	removal torque after 1 h
2896	15-17 in.lbs	16 – 24 kg	12 – 20 in lbs

Product Specification Secure Flip 28mm PCO 1881 Ref.: 2896 V5	Rev. 1 09.07.2018 page 4 of 5	 RPC OBRIST TIMISOARA
--	--	---

Customer drawing

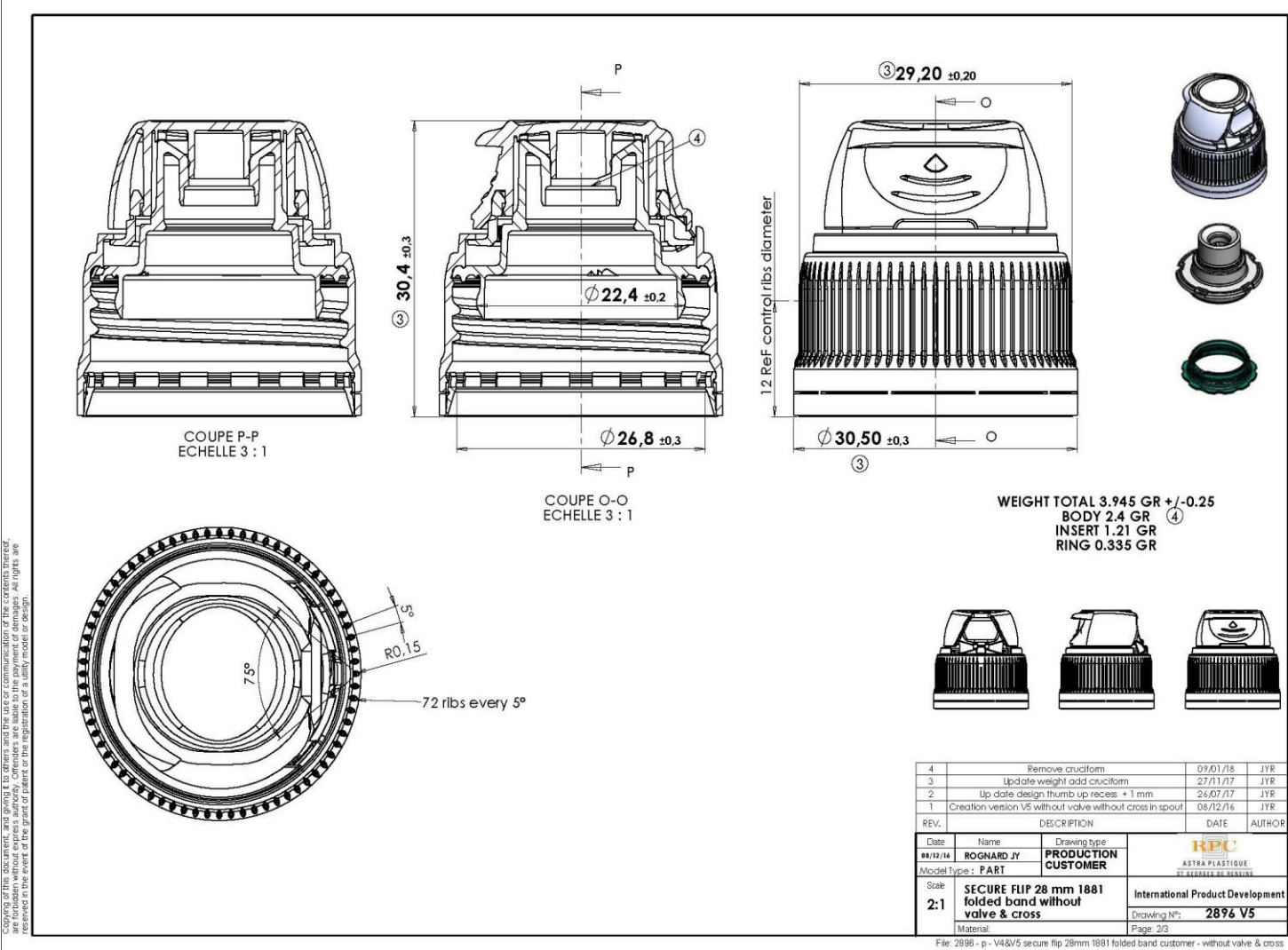

<p>Product Specification</p> <p>Secure Flip 28mm PCO 1881</p> <p>Ref.: 2896 V5</p>	<p>Rev. 1</p> <p>09.07.2018</p> <p>page 5 of 5</p>	
---	---	--

packaging

general remark:

temperature at storage and application must be 18 – 35 °C.

	dimensions	number of boxes	number of caps
pallets one way	1200*800	20	70.000
carton box mm	387*387*588		3500